

Chamfering and deburring tools for gears

Why chamfer and deburr

The reasons for choosing a controlled, high-quality chamfering and deburring process are:

- *To avoid breakage*
 - *Excessive carburizing along the tooth edges can often cause breakage when the gear is running*
- *To avoid damaging gears and bearings*
 - *If burrs are not removed, they may chip off during the running cycle and cause damage to the other gears and bearings.*
- *To avoid poor tool life in the following finishing processes (see next slide)*
 - *Hardened burrs will cause shorter tool life in the following finishing processes*
 - *The build-up of material along the profile due to chamfering must be straightened in a subsequent rolling cycle. If this is not done, such build-up can reduce the life-span of the finishing tools.*
- *Removal of very sharp burrs reduces the risk of tool handling injuries*

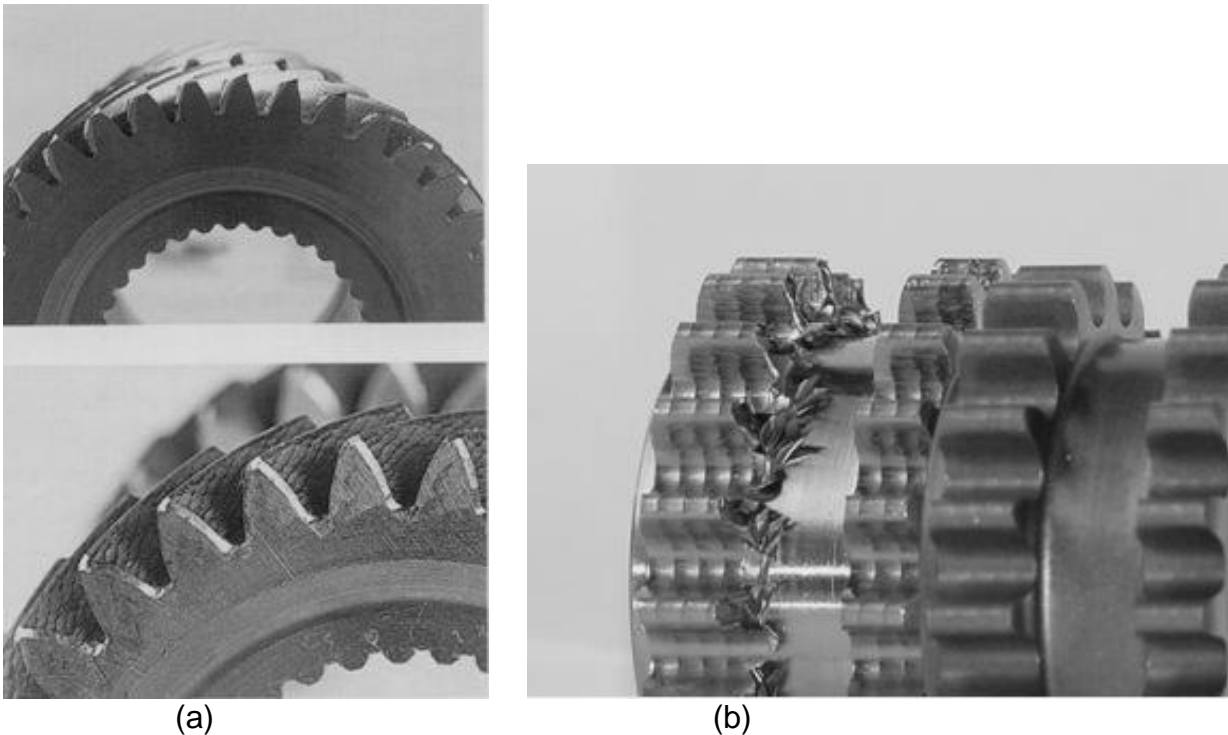

Figure N°1- *Gears with burrs*

In figure N°1 (a) are shown two gear, one before chamfering and deburring operation and the second after these operation.

Figure N°1 (b) shows a gear with a big burr.

Basically there are different types of chamfer: in only one or in both flanks, with a constant size along the profile, with or without chamfer in root diameter.

The figure N°2 shows these different possibilities.

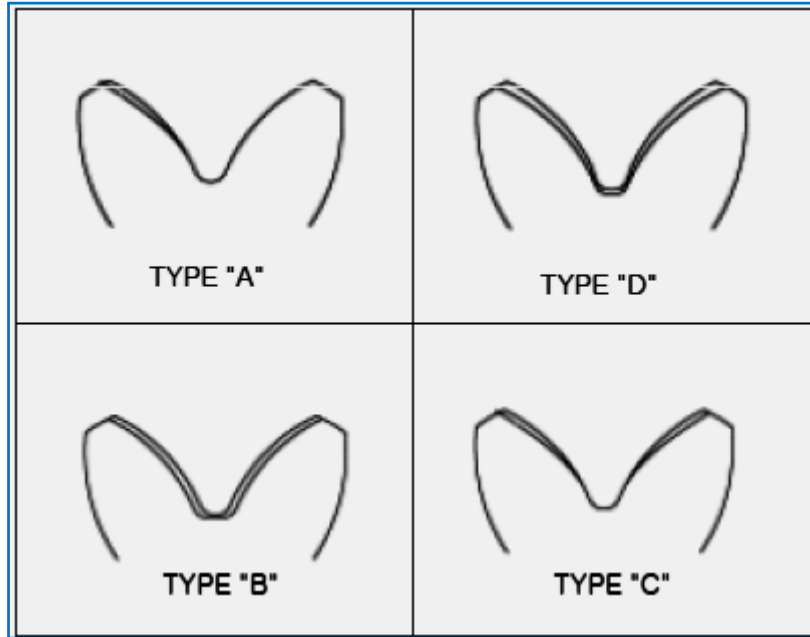
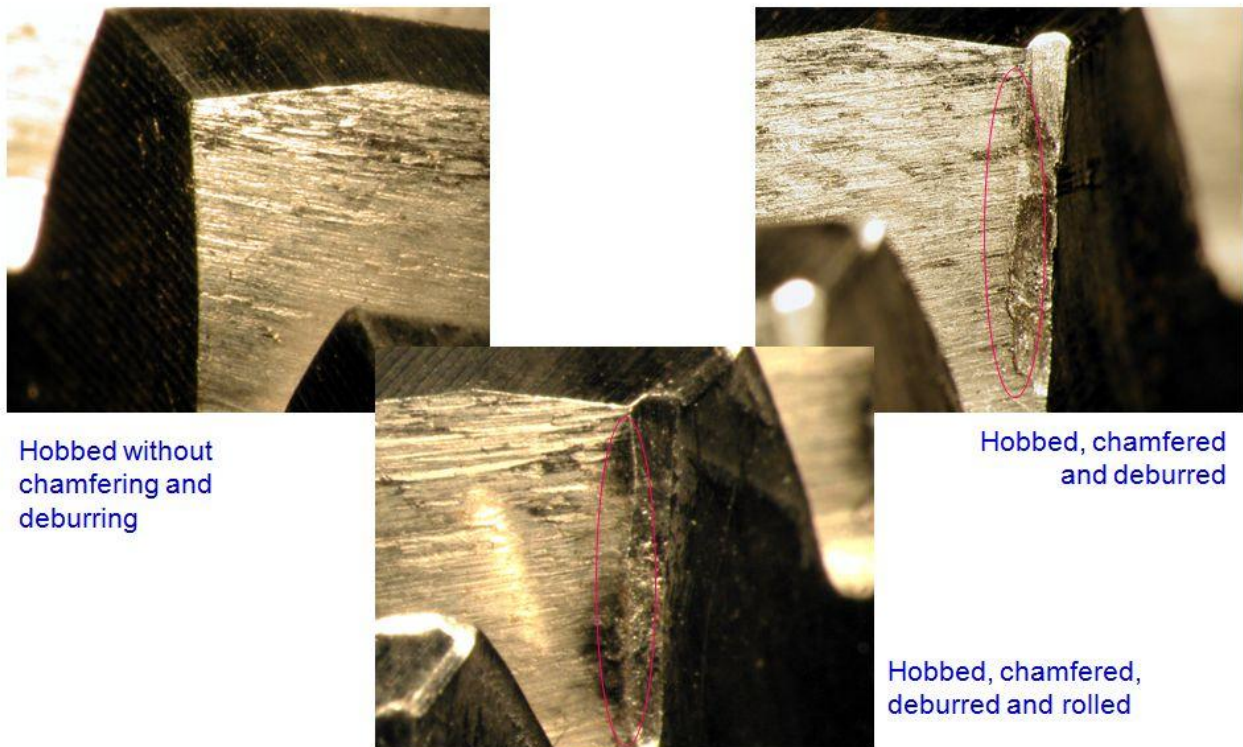

Figure N°2- *Different types of chamfer*

Some time is requested a rolling operation with a special chamfer-roller tool (see the description of this tool in this web site).

The figure N°3 shows a tooth of gear in three different conditions.



Hobbed without
chamfering and
deburring

Hobbed, chamfered
and deburred

Hobbed, chamfered,
deburred and rolled

Figure N°3- *Tooth of a gear in three different conditions*

The chamfering tool generates the chamfer through a compression of the edge.
The pressure and the deformation of the material may modify the structure of the steel.

The chamfering tool is like taper gear, with a width of roughly 10 – 15 mm, and normally is very well finished, with a surface like a mirror in order to prevent a quickly wear . The figure N°4 shows a pair of these tools.



Figure N°4 – A pair of chamfering tools

The angles of the chamfers are definite by the tool drawing, but the size depend on the rolling time and the pressure of the tool against the gear. If the contact time between the tool and piece increase the chamfer becomes bigger. The pressure which defines the deformation force, has generated by a pneumatic cylinder. This method guarantees an “elastic force” that prevents some breakages. The sketch of figure N°5 indicates the position of tool between two gear teeth.

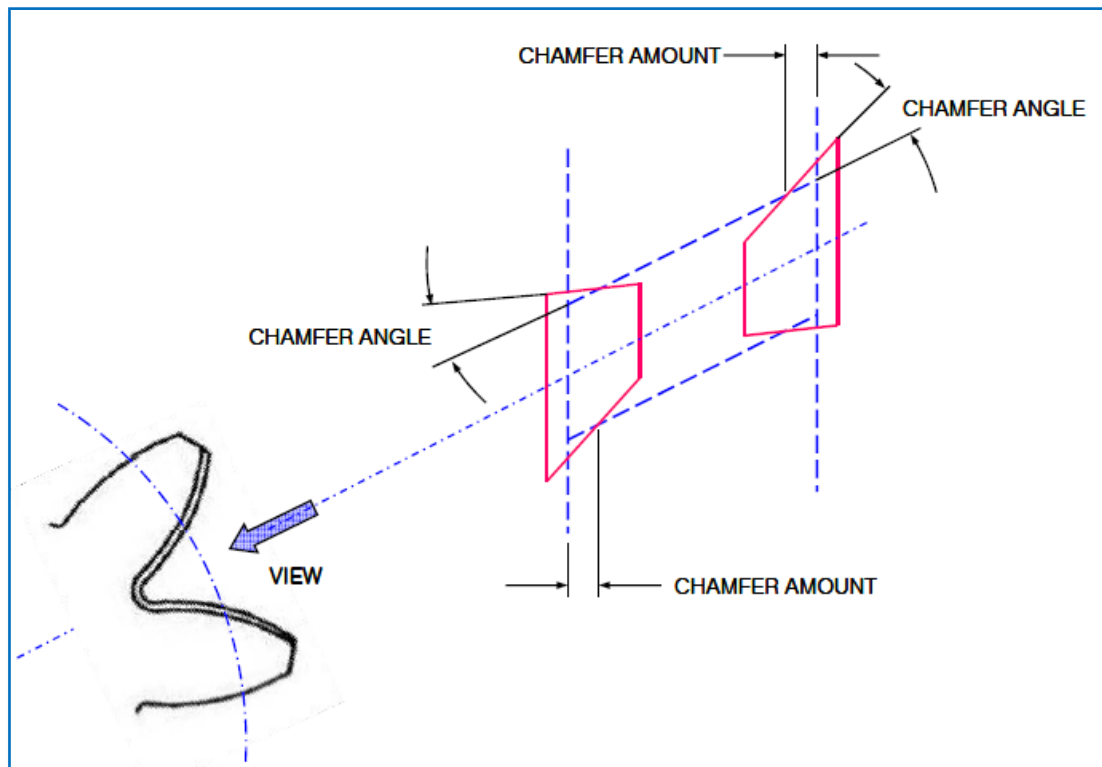

Figure N°5- Position of tools between two teeth of gear



Figure N°6- *Chamfering tool*

Self centered tools guarantee symmetrical chamfers on both sides of the work piece even in the instance of slight displacements between adjacent teeth (for example in a cluster gear). This results in symmetrical and constant chamfer in all teeth.

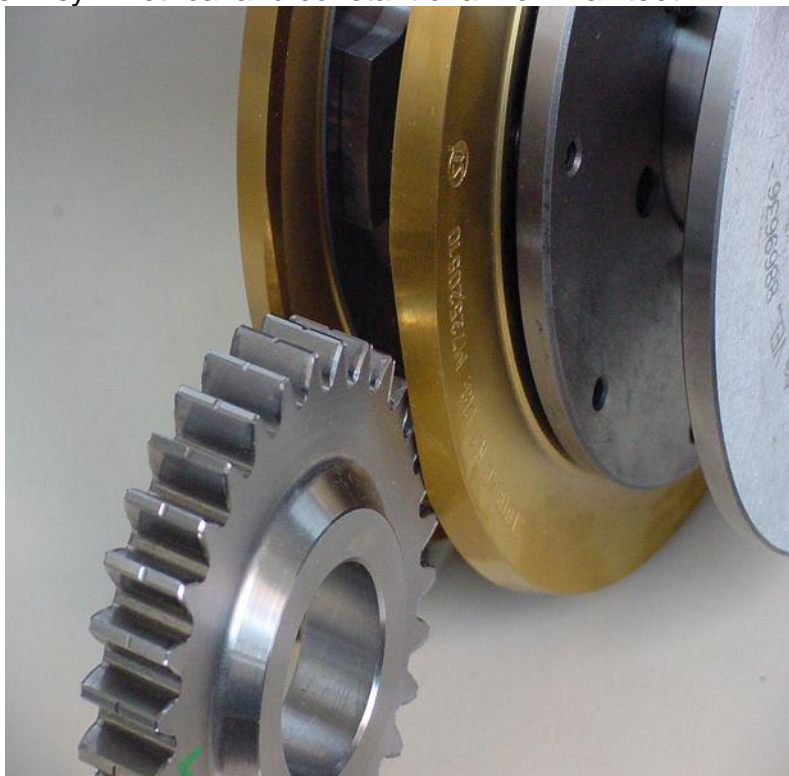
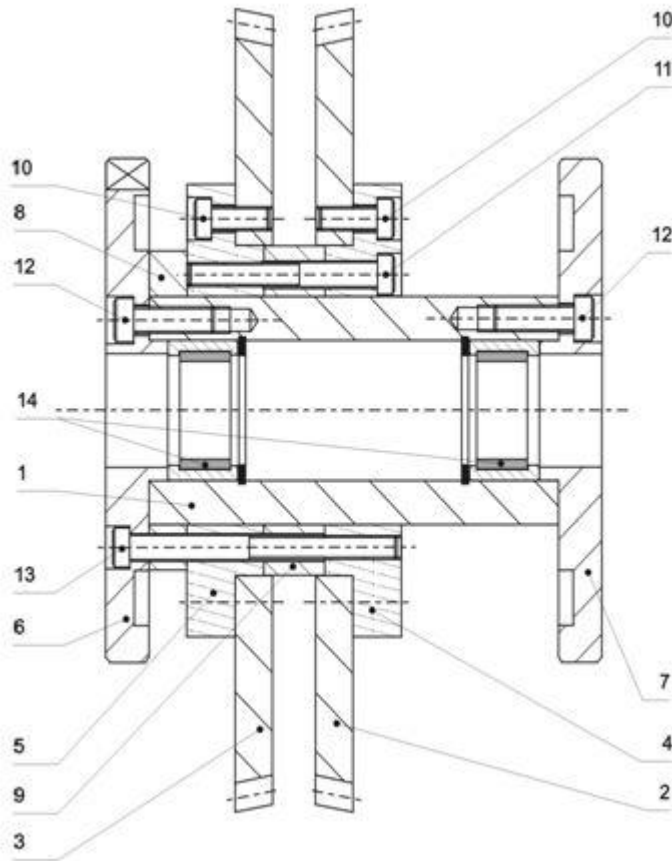

Figure N°7 *Deburring tools*

It's possible to assemble the chamfering and deburring tools in two different heads or in one single tool- holder like the following figures.



- 1 Main body
- 2 Chamfering tool
- 3 Chamfering tool
- 4 Left-hand support
- 5 Right-hand support
- 6 Synchronisation disc
- 7 Clamping disc
- 8 Distance ring
- 9 Distance ring
- 10 Screw M6 x 8
- 11 Screw M6 x ...*
- 12 Screw M6 x 15
- 13 Screw M6 x ...*
- 14 Ball bearing
- * Varies according to work-piece width

Figure N°8- Tool holder for chamfering tools

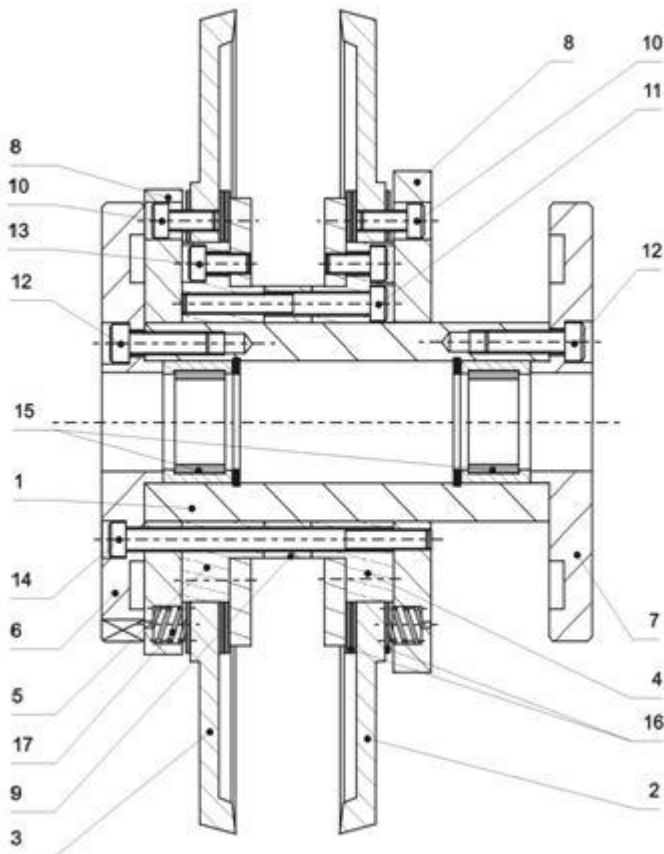

- 1 Main body
- 2 Deburring tool
- 3 Deburring tool
- 4 Right-hand support
- 5 Left-hand support
- 6 Synchronisation disc
- 7 Clamping disc
- 8 Distance ring
- 9 Distance ring
- 10 Screw M6 x 8
- 11 Screw M6 x ...*
- 12 Screw M6 x 15
- 13 Screw M6 x ...*
- 14 Ball bearings
- 15
- 16
- 17
- * Varies according to the work-piece width

Figure N°9 - Tool holder for deburring tools

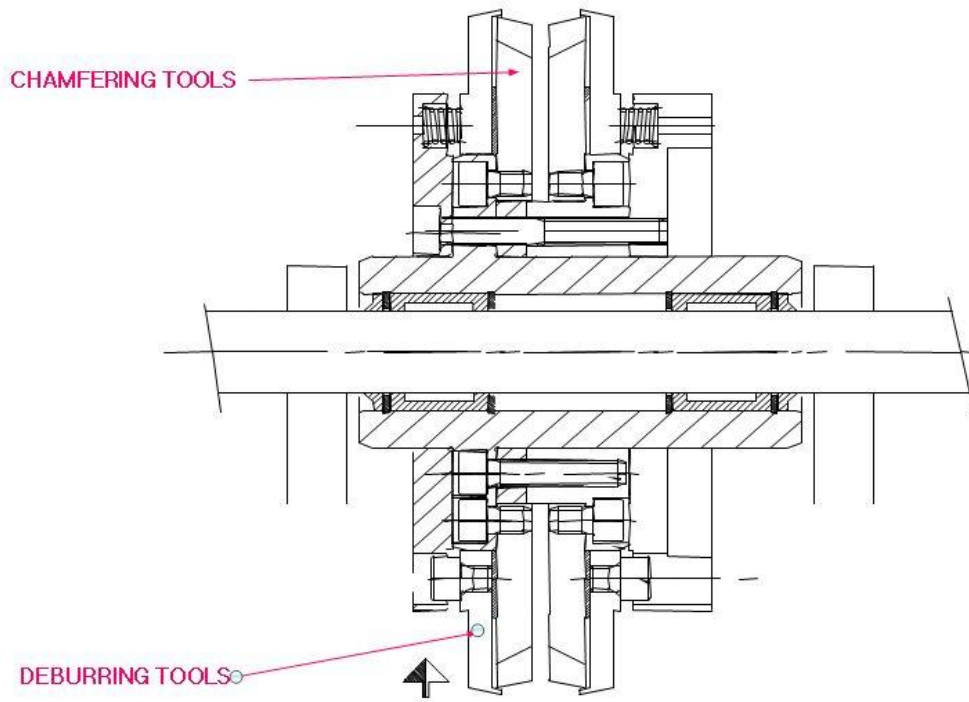

Figure N°10- *Chamfering and deburring tool in the same tool holder*