

Some information about Carbide End Mills

Carbide End Mills are manufactured by Cerin S.p.A (Affi – Verona – Italy) with a special “micrograin carbide” of the DIN groups K10 – K30.

Normally this kind of mills are also coated with different films like TiN, TiCN, TiAlN or CrN in accordance with the request of each specific working operation.

- *TiAlN (Titanium and Aluminium Nitride): Very hard material (3300 HV) with low heat conductivity and good coefficient of friction. It stands very high machining temperatures and is suitable also for dry cutting. For high speed machining and abrasive materials.*
- *TiN (Titanium nitride). Tough and strongly adhesive coating with low thermal conductivity. Its hardness is 2500 HV and is suitable for medium-high cutting speed tools.*
- *TiCN (Titanium carbo-nitride). Tough and strong multi-layer coating. It is very hard material (3250 HV) with a low coefficient of friction. Suitable for steel machining at medium cutting speed and coolant.*
- *CrN (Chromium nitride). Very tough coating. Hardness 1800 HV. Low coefficient of friction and good resistance to high machining temperatures. Good abrasion resistance.*

Milling is one of the most important machining operations. It takes place through the combination of the cutter's rotary motion and the feed longitudinal movement from the work support table.

Chip-forming is interrupted and the chip has the typical “comma” shape.

Milling is performed in the following two ways:

1)- Climb milling

Cutter rotation and work feed have the same direction. The cutter machines the material at the maximum chip thickness and leaves it at the minimum.

The characteristics of this method are:

- *Less vibration*
- *Good surface quality*
- *Longer life of cutting edges*
- *Possible higher cutting speed*

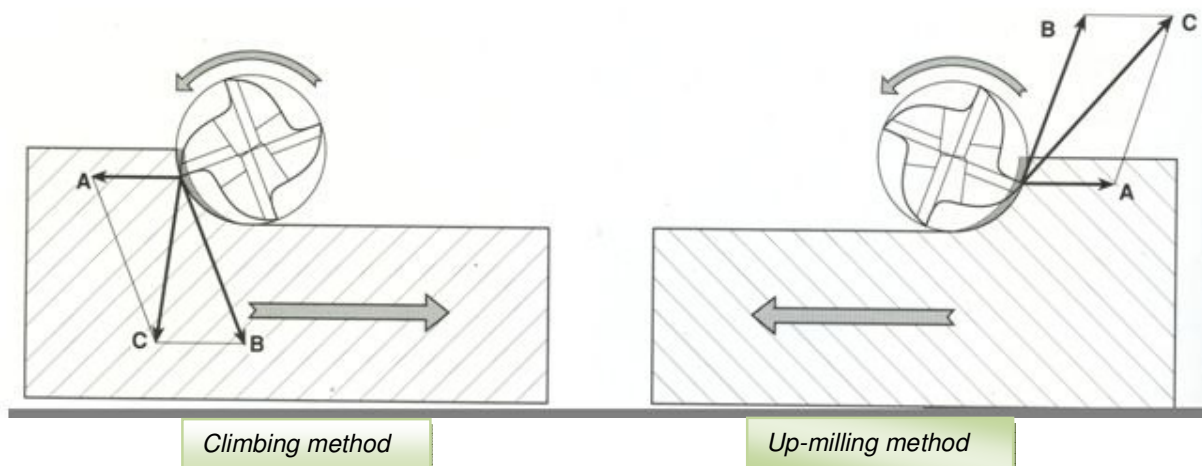

Fig. N°1- *Climbing and up-milling methods*

2)- Up-milling

Cutter rotation and work feed have opposite directions. The material is cut at the minimum thickness and left at the maximum.

The characteristic of this method are:

- *More vibration due to increased shear stress*
- *Shorter life of cutter due to higher wear of cutting edges in the first working length*
- *The vertical shearing stress component tends to detach the workpiece from the table.*

Cerin S.p.A. has also developed a special end mill cutter called Piraña.

The main characteristic of this type of end mill cutter are:

- *High helix angle of the flute (45°)*
- *Irregular pitch of the flute*
- *One cutting edge arrive to the axis of the mill cutter.*

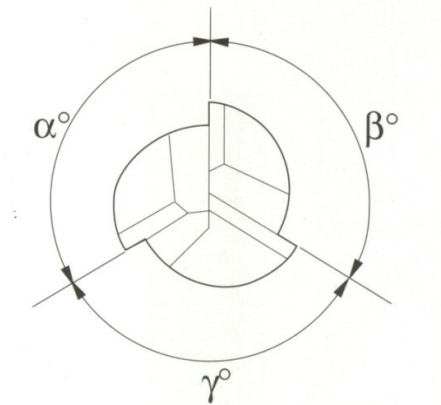

Fig. N°2a- *Cutting edges of “Piraña” end mills cutter*

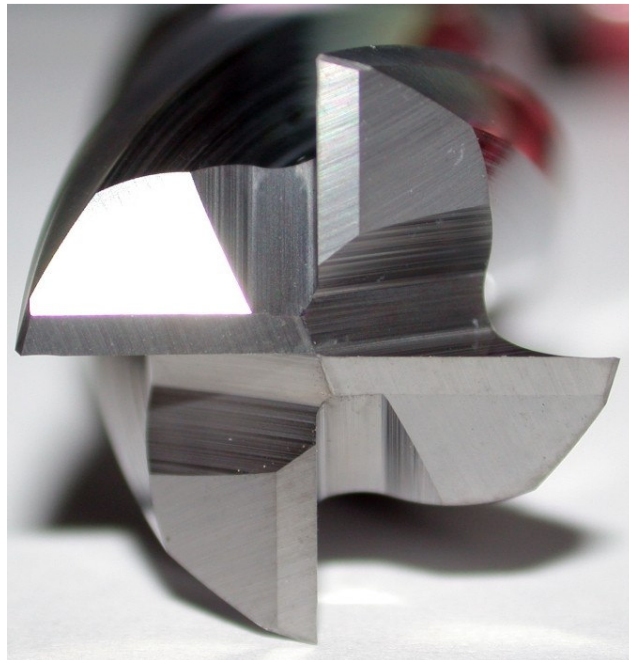

Fig. N°2 b- *Cutting edges of “Piraña” end mills cutter*

The geometrical characteristic of this tool produces a better surface finish thanks to vibrationless of cutting action.

The shape was specially researched to ensure easy chips clear out in order to guarantee a smaller coefficient of friction during machining.

There are a lot of technical characteristic of a end mill cutter, but the most important are the number of flutes and the helix angle of the flutes.

For each type is suggested a different value of stock removal and length of contact, as shown in the figure N°3.

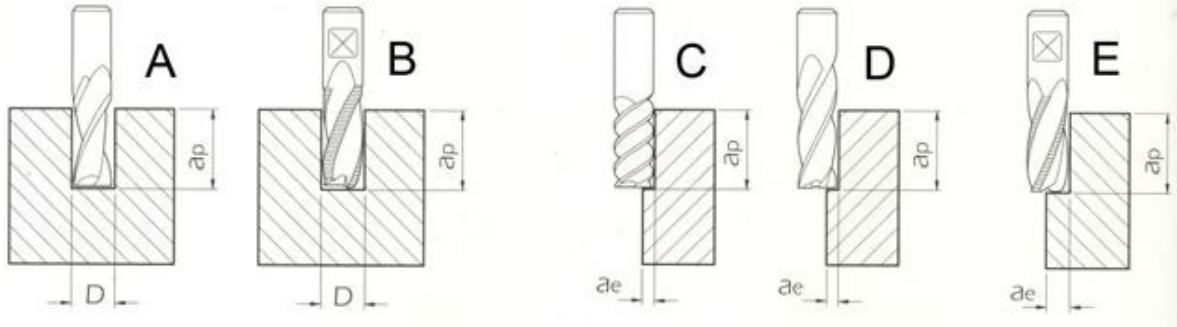

- A = 2 flutes – Helix angle 30° : $a_p = 0,75 D - 1,0 D$
- B = 3 flutes - Helix angle 30° (roughing type): $a_p = 0,75 D - 1,2 D$
- C = 3 flutes – Helix angle 55° : $a_p = 1,5 D$; $a_e = 0,02 D - 0,03 D$
- D = 4 flutes – Helix angle 30° : $a_p = 1,5 D$; $a_e = 0,1 D - 0,15 D$
- E = 4 flutes - Helix angle 30° (roughing type): $a_p = 1,5 D$; $a_e = 0,3 D - 0,4 D$

Fig: N°3



Fig. N°4- Group of different types of end mill cutter

End mill geometry

In the figure N°5 is shown the main geometrical characteristic of a end mill cutter.

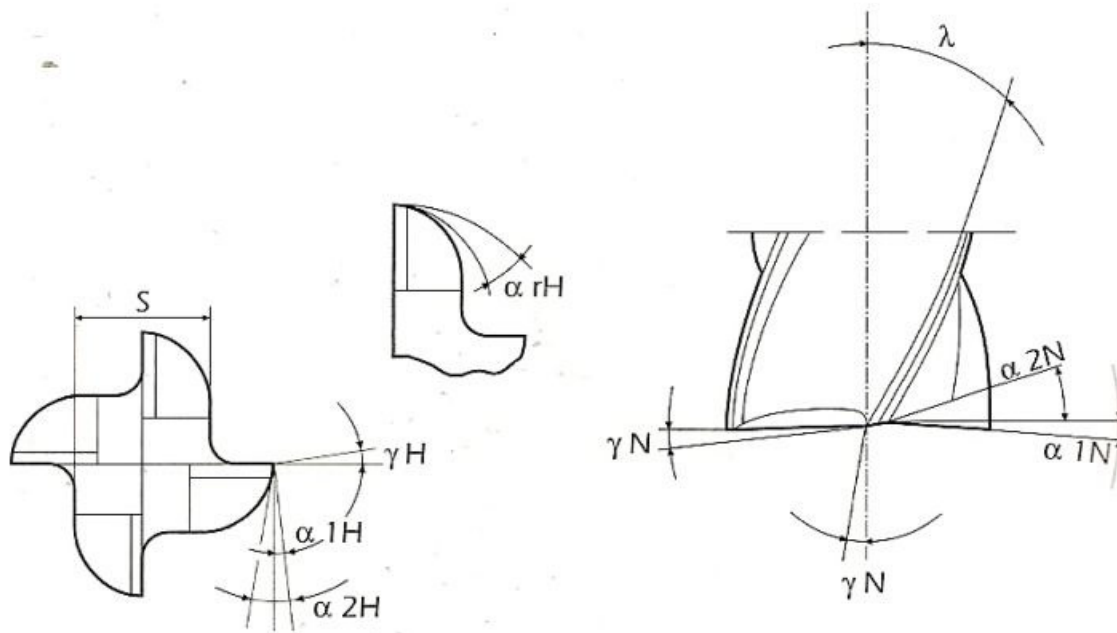

$\alpha 1H$	Primary rake angle on diameter
$\alpha 2H$	Secondary rake angle on diameter
αrH	Radial rake angle
γH	Internal rake angle
$\alpha 1N$	Primary frontal rake angle
$\alpha 2N$	Secondary frontal rake angle
γN	Undercut angle to the center
λ	Helix angle
S	Core diameter

Fig. N°5- End mill geometry

Working condition

For each milling operation we must decide the cutting speed and the feed per tooth.

These two parameters are linked to many condition, like: the diameter of the tool, the type of coating (if there are), the material machined, the type of coolant and so so.

In the table N°1 there are the suggested working conditions in the case of tools without coating.

In the table N°2 we have the working conditions in according with different types of coating.

Of course all values are indicative, means that the best working condition must be found through some test.

Table N^o1- Working conditions for non coated end mill

Material	Cutting speed Vc - m/min	FEED PER TOOTH ACCORDING TO DIAMETER							Coolants
		Ø 2	Ø 5	Ø 8	Ø 10	Ø 12	Ø 16	Ø 20	
Steel up to 500 N/mm ²	80-90	0,02	0,04	0,06	0,08	0,08	0,10	0,10	emulsion
Alloy steel over 500 N/mm ²	50-60	0,01	0,02	0,04	0,04	0,05	0,08	0,08	emulsion
Tool steel	40-50	0,01	0,02	0,02	0,03	0,04	0,05	0,05	oil
Hardened steel	40-50	0,01	0,05	0,020	0,025	0,025	0,030	0,05	oil
Spring steel	40-50	0,01	0,02	0,03	0,04	0,05	0,06	0,08	oil
Cr-Ni steel - Stainless steel	30-40	0,01	0,015	0,02	0,03	0,04	0,05	0,06	emulsion
Alloy steel special alloys	20-40	0,01	0,015	0,02	0,025	0,03	0,03	0,04	oil emulsion
Semisteel cast iron	50-70	0,01	0,02	0,03	0,05	0,08	0,10	0,12	emulsion
Cast iron up to 200 HB	60-70	0,02	0,04	0,05	0,06	0,08	0,10	0,15	dry/emulsion
Cast iron over 200 HB	50-70	0,02	0,03	0,04	0,05	0,06	0,8	0,10	dry/emulsion
Cast iron up to 500 HB	40-50	0,02	0,03	0,04	0,05	0,06	0,07	0,08	dry/emulsion
Cast iron over 500 HB	40-50	0,02	0,03	0,04	0,05	0,06	0,07	0,08	dry/emulsion
Copper / bronze / brass	100-120	0,02	0,04	0,05	0,06	0,08	0,10	0,15	emulsion
Aluminium alloys up to 11% Si	80-100	0,03	0,06	0,08	0,10	0,12	0,15	0,15	emulsion
Aluminium alloys over 11% Si	80-100	0,02	0,04	0,06	0,08	0,10	0,12	0,15	emulsion
Titanium and titanium alloys	20-30	0,01	0,02	0,04	0,05	0,06	0,08	0,10	emulsion
Plastic materials Thermosetting	150-200	0,02	0,04	0,06	0,08	0,10	0,12	0,15	dry
Epoxy resin and reinforced fibers	120-150	0,02	0,03	0,04	0,06	0,08	0,10	0,12	dry

Tab. N^o2- Working condition for coated end mill

Material	TiAlN		TiN		TiCN		CrN		Coolant
	Cutting speed m/min.	Feed per tooth Ø 2-4-6	Cutting speed m/min.	Feed per tooth Ø 8-10-12	Cutting speed m/min.	Feed per tooth Ø 16-18-20	Cutting speed m/min.		
Steel up to 500 N/mm ²	120	0,02-0,04	100	0,06-0,08	110	0,10-0,12			emulsion
Alloy steel over 500 N/mm ²	100	0,02-0,03	80	0,04-0,05	90	0,06-0,08			cutting oil emulsion
Tool steel	80	0,01-0,03	60	0,04-0,06	70	0,07-0,08			cutting oil
Hardened steel	80	0,01-0,02	60	0,03-0,04	70	0,05-0,06			cutting oil
Spring steel	70	0,01-0,02	50	0,03-0,04	60	0,05-0,06			cutting oil emulsion
Cast iron up to 200 HB	90	0,03-0,05		0,06-0,08		0,10-0,15			emulsion
Cast iron over 200 HB	90	0,02-0,04		0,05-0,07		0,08-0,10			emulsion
Cast iron up to 500 HB	80	0,02-0,05		0,06-0,08		0,10-0,12			emulsion
Cast iron over 500 HB	80	0,01-0,04		0,05-0,06		0,08-0,10			emulsion
Aluminium alloys up to 11% Si	250	0,03-0,08	200	0,10-0,12		0,15-0,20			dry emulsion
Aluminium alloys over 11% Si	200	0,02-0,07	150	0,08-0,10		0,15-0,20			dry emulsion
Aluminium castings	200	0,02-0,05	150	0,06-0,08	200	0,10-0,15			emulsion
Copper	230	0,02-0,04		0,06-0,08		0,10-0,15	180		emulsion
Bronze / silver	250	0,02-0,08		0,10-0,12	200	0,15-0,25			dry emulsion
Brass / zinc / nickel	200	0,02-0,04		0,06-0,08		0,10-0,20	150		emulsion
Titanium	40	0,01-0,02		0,03-0,05		0,06-0,08	30		emulsion

In the following table we show the most common problems found during end mills operation.

Table N°3

<i>Problem</i>	<i>Solution</i>	
	<i>Decrease</i>	<i>Increase</i>
Cutting edge chipping	Feed per tooth	Cutting speed Carbide toughness Cutting edge phase Machine stability
Cutting edge wear	Cutting speed	Feed per tooth Carbide wear resistance Cutting edge phase
Wear crater type	Cutting speed Feed per tooth	Carbide wear resistance Coolant pressure
Chip welds on the cutting edge	Cutting depth	Cutting speed Feed per tooth Coolant pressure
Bad workpiece surface	Feed per tooth Cutting edge phase Cutting depth	Cutting speed Machine stability Helix angle Mill cutter concentricity Number of flutes
Vibrations	Cutting depth Cutting speed	Machine stability Workpiece stability Coolant density
Workpiece chipping	Feed per tooth Cutting edge phase Cutting depth	
Sovraccarico della macchina	Cutting speed Feed per tooth Cutting depth	