

Worm wheel hobs

Worm wheel hobs need slightly more explanation than the other types of hob, in fact this type of hob have some very peculiar characteristic of which technicians must be aware. It is to be found relatively frequently in workshop since it is used for a component of speed reducers which are utilized in a very wide range of sectors.

It is firstly necessary to point out that there are four different types of worms which have different profiles and the geometry of which is defined by the DIN 3975 normative.

The figure N°1 shows a worm and its technical characteristics

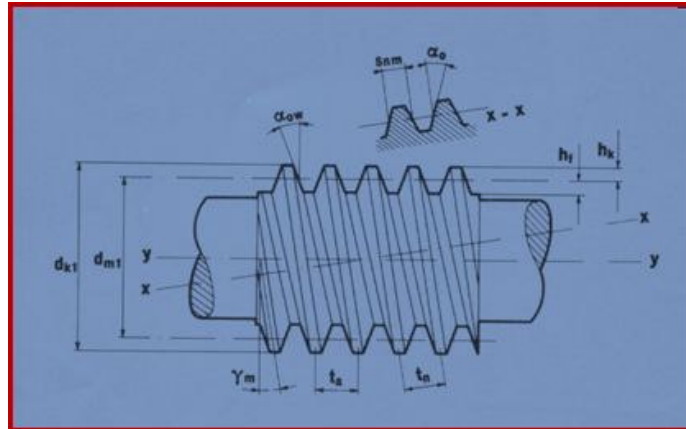

Fig. N°1

$x - x$	Normal section	α_{0w}	Axial pressure angle
$y - y$	Axial section	hk	addendum
$dm1$	Pitch diameter	hf	dedendum
$dk1$	Outside diameter	mn	Normal module
tn	Normal pitch	ms	Axial module
ta	Axial pitch	$z1$	Number of threads
snm	Normal tooth thickness on $dm1$	r	Right hand helix
γ_m	Helix angle	l	Left hand helix
α_0	Normal pressure angle	$z2$	Number of gear teeth

Flank form A (worm ZA)

As shown in figure N°2, the worm has straight-sided flanks in an axial section. This flank form is obtained by cutting the worm with a turning tool (a) which has a straight-sided cutting flank on a diametrical plane (orthogonal to the axis) $x - x$.

The worm could also be cut with a cutter with involute flanks which is placed on a diametrical plane $x - x$.

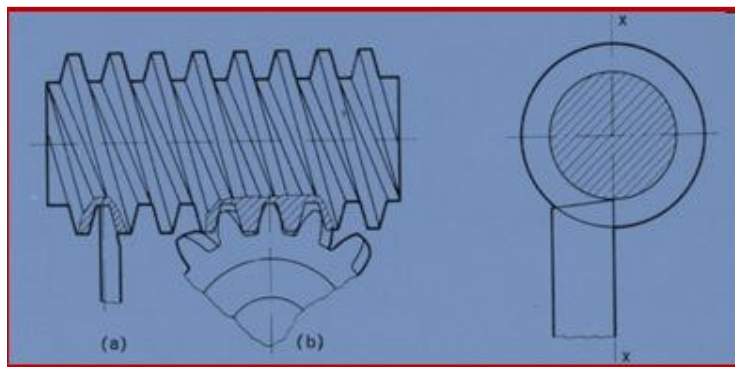

Fig. N°2

Flank form N (worm ZN)

The worm has straight-sided flanks in a section that is perpendicular to the helix of the thread. This form is obtained by using a trapezoidal turning tool placed at the height of the axis in the vane between two threads and inclined at the average helix angle γ_m (figure N°3a), or a good level of approximation may be obtained with an end milling cutter (figure N°3b) or with a small diameter disk-type milling cutter (figure N°3c).

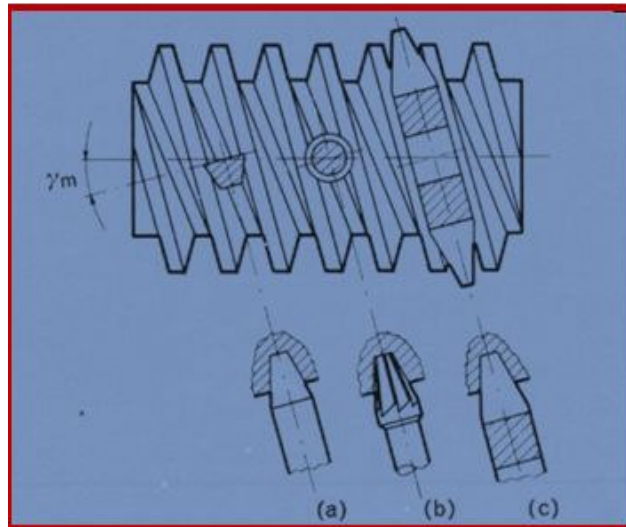

Fig. N°3

Flank form K (worm ZK)

This is obtained with a grinding wheel or with a large diameter milling cutter with straight-sided flanks inclined by an average angle γ_m (figure N°4). The flanks that are obtained are slightly convex and the amount of this convexity is determined according to the helix of the thread and to the diameter of the tool. The smaller the tool's diameter is, the closer this type of profile will be to N type.

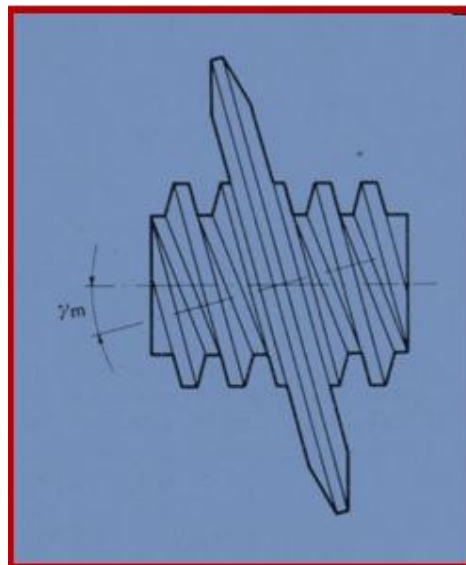

Fig. N°4

Flank form E (worm ZE)

The worm has involute flanks like a gear with helicoidal teeth and an helix angle equal $(90 - \gamma_m)$. It's obtained enveloping with a hob or by grinding with a grinding wheel which has the straight-sided flanks and inclined of the same value of the pressure angle and the helix angle (fig. N°5-a). It may also be machined with a turning tool that has asymmetric-sided flanks lying on a plane $x_g - x_g$ and which are tangent to the base diameter (figure N°5-b).

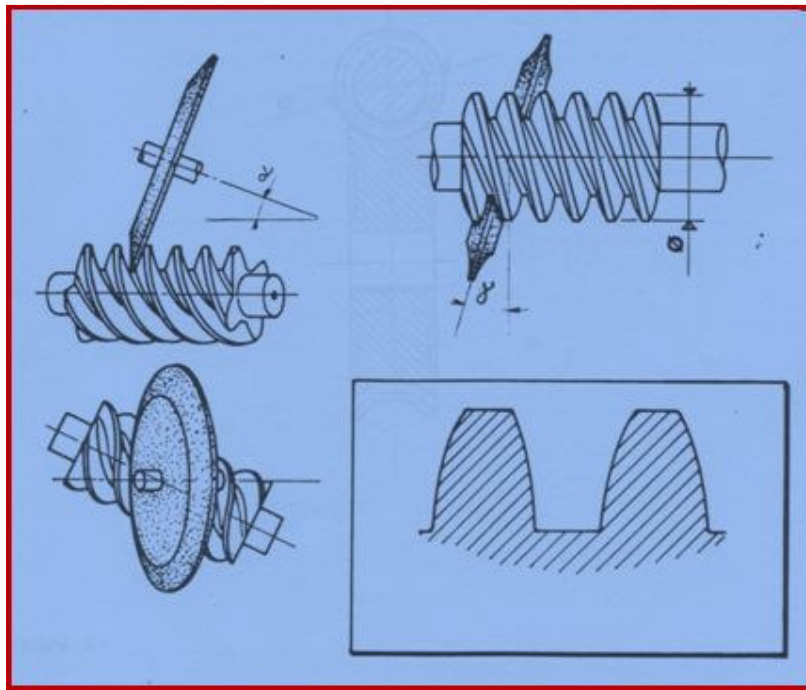

Fig. N°5-a

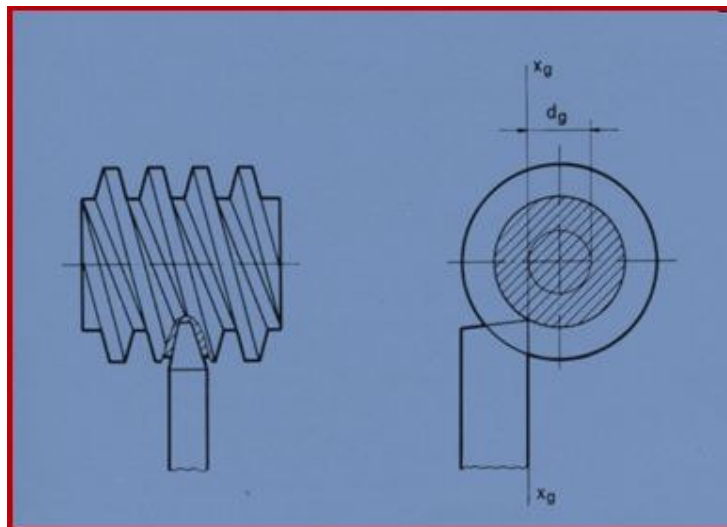

Fig. N°5-b

Helical worm wheels

Wheels that are to be mated with the worms described above are called helical worm wheels. Cutting these wheels is possible thanks to the fact that the hob itself is an endless screw. The essential data of the hob is therefore the same as that of the worm which means that the helical worm wheel produced is perfectly suitable for mating.

To do this the hob is given a rotary motion and the wheel is made to turn in synchronization with the hob, reproducing the rotation that occurs between the wheel and the worm.

The big difference between this type of hobbing and generating cutting of cylindrical gears is that when cutting cylindrical gears the hob may have any pitch diameter while worm wheel hobs must have the same pitch diameter – or at least a very close pitch diameter – to that of the worm with which the wheel will mate.

In general the diameter of the worm and therefore of the hob is small enough not to have a keyed bore. The hobs will therefore be shank-type as shown in figure N°6.

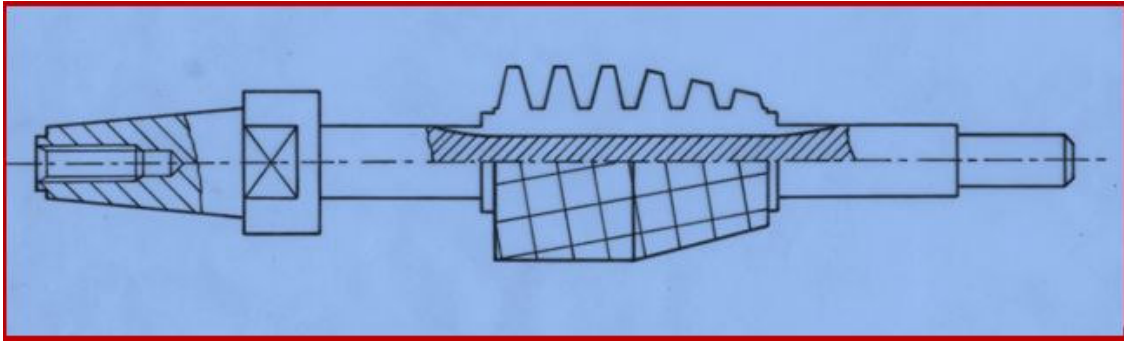

Fig. N°6

Type of feed

It is possible to cut helical worm gear in three different manners: with radial feed, with tangential feed and with combined radial and tangential feed.

A cylindrical hob is used to cut with *radial feed*, like that shown in figure N°7.

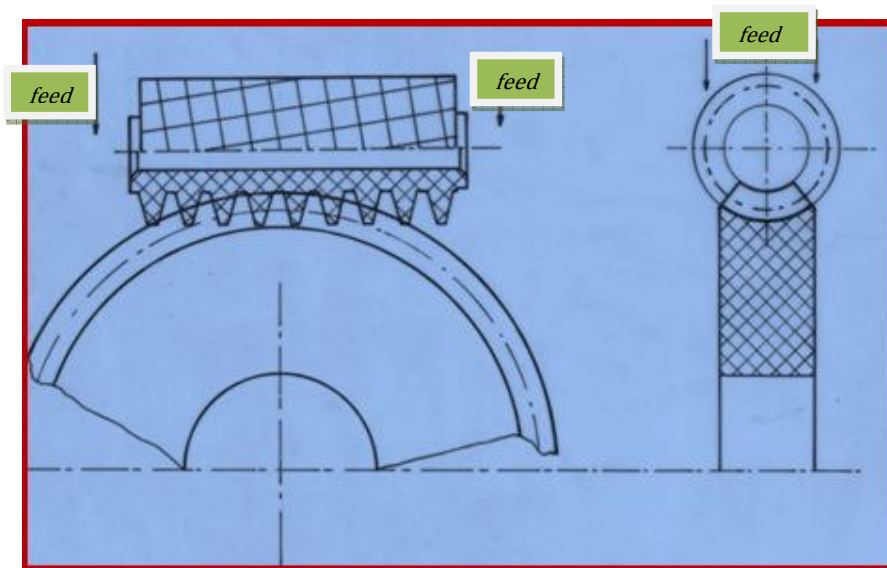

Fig. N°7

Very low cutting times with extremely high hourly production rates are obtained with this system since the passive time needed for the hob to approach the workpiece is eliminated.

The application of this system is, however, limited to helical worm gear manufacturing with a maximum helix angle of 6 – 8° as if this limit were exceeded, intolerable interference between the hob and the gear would be generated.

This interference is due to the fact that the helix angles measured on various diameters are different. Therefore, at the beginning of manufacturing, the hob removes a part of the material which should constitute part of the tooth flank at the end of radial stroke.

The limits mentioned above which cannot be used with this method are:

- For a pressure angle of 15°: helix angle no more of 6°
- For a pressure angle of 20°: helix angle no more of 8°

For finishing operations where high mating accuracy is required, it is best to apply axial feed also for lower helix angles.

In any case, when machining with radial feed the hob must protrude above the axis of the gear by a certain entity X which must definitely be higher than the overlap. Its value depends both on the helix angle and on the axial pitch. The overall useful length of the hob therefore has to be at least 2X. The relation between these elements is shown in the table N°1.

Cutting helical worm gear with the radial method may be performed on normal hobbing machine.

Table N°1 – Calculation of the minimum protrusion

<i>N° of teeth</i>	<i>Less or equal of 30</i>		<i>More of 30</i>	
<i>Pressure angle</i>	15°	20°	15°	20°
<i>Minimum protrusion X</i>	$2,25 \cdot P_a$	$1,75 \cdot P_a$	$2,60 \cdot P_a$	$1,90 \cdot P_a$

The scheme of *tangential feed* is illustrated in figure N°8, where we can see that the feed of the hob is in the same direction as its own axis. First of all this method has the advantage of the hob always being with its pitch diameter tangent to the pitch diameter of the gear. The hob approaches, roughing the teeth with the tapered section and finishing it with the cylindrical section which makes penetration more gentle.

Secondly the number of enveloping tangents of the tooth profile no longer depends on the number of gashes of the hob but on the feed speed which makes it easier to obtain the desired level of finishing.

The fundamental disadvantage of this method, however, is that it takes longer.

To carry out the tangential (or axial) method, it is necessary to use special hobbing machines which are equipped with differential gears that not only give the workpiece normal mating rotation but also supplementary rotation which compensates for the feed of the hob.

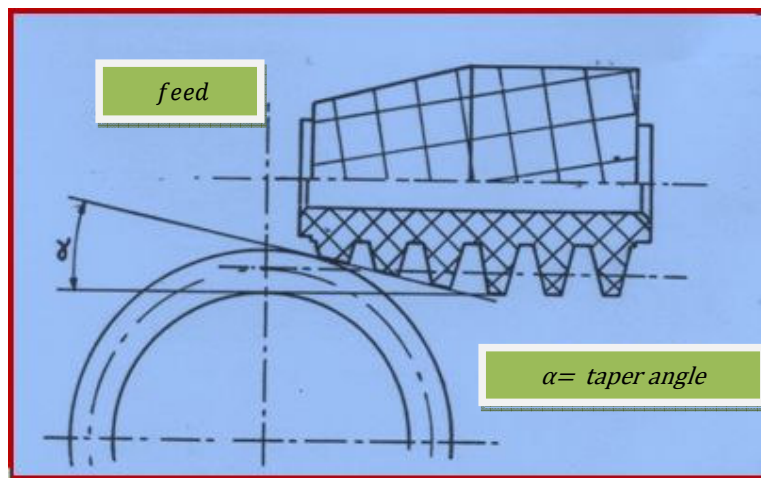

Fig. N°8

Of course with the modern numeric control hobbing machines this problem is easily overcome.

The speed of this additional rotation must be such that the peripheral speed of the gear measured on the pitch diameter is equal to the feed speed of the hob.

The length of the cylindrical section of the hob must not be less than the protrusion X as per the table N°1.

It's possible to work with a combination of radial and axial feed. A cylindrical hob is Also used for this method. As illustrated in figure N°9 the hob roughs the workpiece with radial feed and finishes it with axial feed.

Hobbing times are lower than with the previous method even though the profile generated is accurate.

With this method however, the same limitation as with the radial method applies, that is intolerable interference above a certain helix angle.

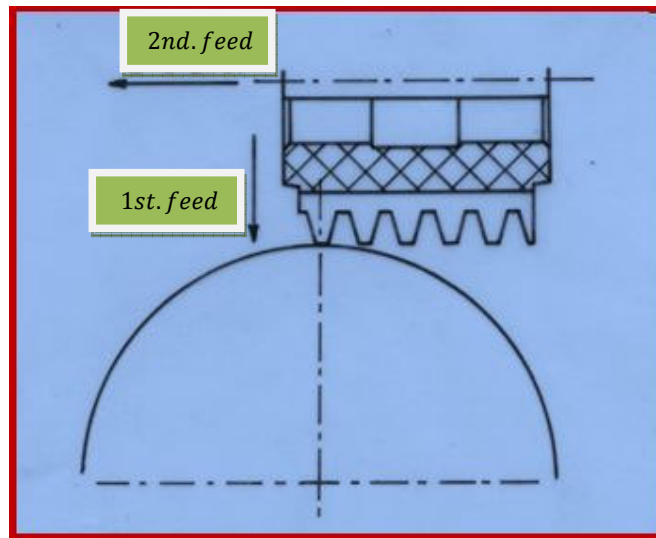

Fig. N°9

Taper

With the tangential method, as has already been mentioned, the hob has a taper which serves to rough the teeth of the wheel and to make penetration more gentle. The hob tooth thickness in the tapered section is therefore reduced by about 0,8 mm at the beginning of the taper and it gradually decreases until the end of the taper. The teeth in the cylindrical section have the sole task of finishing the teeth.

With tapered hobs it's important to determine the direction of cutting and the direction of the helix in relation to the taper.

In figure N°10 the possible combination between the direction of the helix and the direction of cutting are given.

The cutting direction is determined in the following manner:

- For tapered bore-type hobs observe the rotation from the face without taper: if the rotation is clock-wise, the cutting direction is to the right. If the rotation is anti-clockwise the cutting direction is to the left .
- For shank-type hobs observe the rotation from the part of the shank attachment.

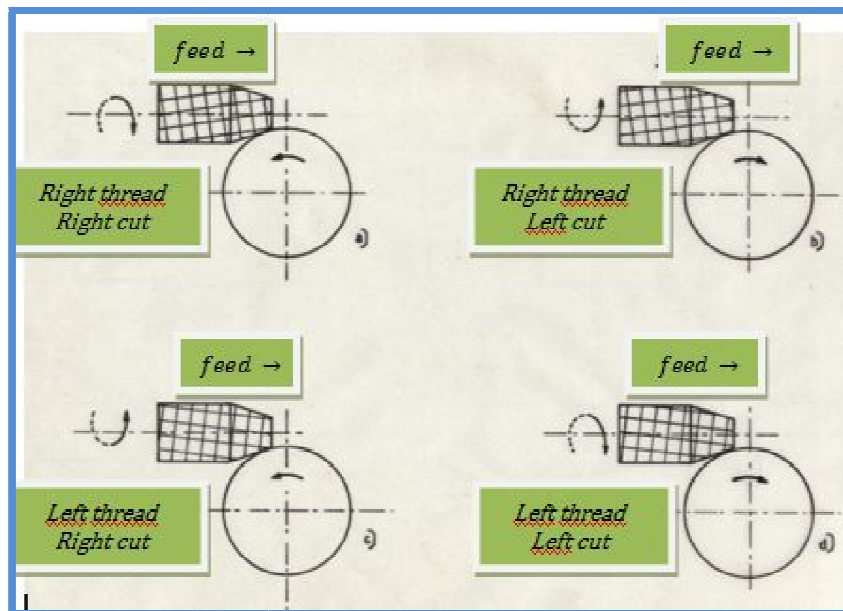

Fig. N°10

Increasing the pitch diameter

In order to have theoretically perfect mating between the worm and the worm wheel it is necessary that the pitch diameter of the hob is the same as the pitch diameter of the worm

The theoretical condition rarely occurs in practice since, as we all know, the hob has a certain tip relief (back relief) and its diameter therefore decreases with each resharpening.

As the pitch diameter of the hob should not be lower than the pitch diameter of the worm in order to avoid very bad mating (contact would only be on the external edges of the tooth), it is necessary to increase the diameter of the new hob so that at the end of its life the pitch diameter is the same as that of the worm.

We usually foresee using a hob tooth for a width which is equal to half distance between two consecutive teeth (resharpening pitch) and therefore the increase in the radius will be half of the back relief measured on a pitch, that is half of the relief cam. The increase on the diameter will be equal to the value of the cam.

With reference to the figure N°11, we have $D_{pn} = d_{m1} + S$ where:

D_{pn} = Pitch diameter of the new hob

d_{m1} = Theoretically exact pitch diameter

S = Back relief on a pitch (value of the relief cam)

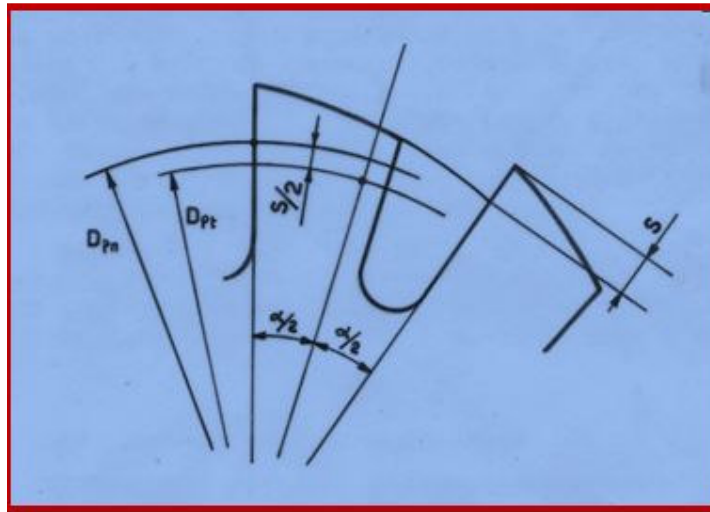

Fig. N°11

Given the difference between D_{pn} and d_{m1} the inclination of the helix of the hob thread will be slightly different to theoretical inclination.

Shank-type hobs for helical worm wheels frequently have a very large thread helix which complicates the resharpening operation.

In fact not all hob sharpening machines can sharpen hob with large helix angle correctly, all the more due to the fact that in these cases it is necessary to correct the profile of the resharpening face precisely; it will, in fact, no longer be flat but convex.

This convexity will depend on the hob diameter, on the helix angle and on the diameter of the grinding wheel.